

Calorie

Gas Range Installation Instructions And Use and Care Manual

To the Installer: Leave this manual and other literature with the consumer for future use.

To the Consumer: Keep this manual for future reference.

RLN330U - RLN330UW - RLN340U - RLN345U
RLN345V - RLN347 - RLN362 - RLN367 -
RLN370 - RLN380 - ~~RLN381~~ - RLN383
RLN385 - RMN380, 381, 383, 385

Table of Contents

Important Safety Instructions	1
Cabinet Cutout and Clearances	3
Making the Gas Connection	4
Making the Electrical Connection	5
Pressure Testing the Gas Supply	5
Testing For Gas Leaks	5
Lighting the Top Burner Standing Pilot Flame	6
Adjusting the Top Burner Flame Size and Shape	6
Lighting the Oven Burner Standing Pilot Flame	7
Adjusting the Oven Burner Flame Size and Shape	7
Converting From Natural Gas to LP/Propane	8
Installing the Anti-Tip Bracket	9
Setting the Time Of Day	10
Selecting Cooking Utensils	10
Using the Top Burners	11
Using the Oven	12
Using the Broiler	14
Cleaning Range Parts	15
Maintenance	16
Before Calling For Service	17
When Service Is Required	18
Asure™ Extended Service Plan	18

Important Safety Instructions

⚠️ WARNING

If the information in this manual is not followed exactly, a fire or explosion may result causing property damage, personal injury or death.

- Do not store or use gasoline or other flammable vapors and liquids in the vicinity of this or any other appliance.

- **WHAT TO DO IF YOU SMELL GAS**
 - Extinguish any open flame.
 - Do not try to light any appliance.
 - Do not touch any electrical switch;
 - Do not use any phone in your building.
 - Immediately call your gas supplier from a neighbor's phone. Follow the gas supplier's instructions.
 - If you cannot reach your gas supplier, call the Fire Department.

- Installation and service must be performed by a qualified installer, service agency or the gas supplier.

⚠️ WARNING

This gas appliance contains or produces a chemical or chemicals which can cause death or serious illness and which are known to the state of California to cause cancer, birth defects, or other reproductive harm. To reduce the risk from substances in the fuel or from fuel combustions make sure this appliance is installed, operated, and maintained according to the instructions in this book.

To avoid the possibility of electrical shock: disconnect the power supply before servicing this unit.

To avoid personal injury, do not sit stand or lean on the oven door, oven drawer or broiler drawer.

To reduce the risk of the appliance tipping, it must be secured by a properly installed anti-tip device. To make sure the device has been installed properly, remove the storage drawer and look under the range with a flashlight. The device must be engaged in the rear corner of the range.

⚠️ WARNING



- ALL RANGES CAN TIP
- INJURY TO PERSONS COULD RESULT



- INSTALL ANTI-TIP DEVICE PACKED WITH RANGE
- SEE INSTALLATION INSTRUCTIONS

**FOR YOUR SAFETY
DO NOT OBSTRUCT THE FLOW OF
COMBUSTION OR VENTILATION AIR.**

NOTICE

The maximum gas supply pressure for these models must not exceed 14 inches W.C.P.

The manual shut off valve must be installed in an accessible location in the gas line external to the appliance for the purpose of turning on or shutting off gas to the appliance.



⚠️ WARNING

General

1. The range must be installed by an authorized servicer.
2. Never use the range for warming or heating the room.
3. Do not store items on the rangetop. Items stored on the rangetop can become too hot and melt.
4. Wear proper apparel. Loose fitting or hanging garments should never be worn while using the range.
5. Do not repair or replace any part of the range yourself unless it is recommended in this manual.
6. Flammable materials should not be stored near the range.
7. Use only dry potholders. Moist or damp potholders on hot surfaces may result in burns from steam. Do not let a potholder touch a flame. Do not use a towel or a bulky cloth as a potholder.

Surface Cooking

1. Use the proper pan size. Select utensils with flat bottoms large enough to cover the flame. Undersized utensils will expose the flame to direct contact with clothing.
2. Never leave surface units unattended at high heat settings. Boilovers can cause smoking and may ignite.
3. To reduce the risk of burns, ignition of flammable materials or spillage due to unintentional contact with the utensil, utensil handles must be turned inward and extend over adjacent surface burners.
4. Only certain types of glass, glass/ceramic, ceramic, earthenware, or other glazed utensils are suitable for rangetop use. Unsuitable utensils may break due to the sudden temperature change.
5. Clean the rangetop with caution. To avoid steam burns, do not use a wet sponge or cloth to wipe up spills on a hot cooking area.
6. Do not place aluminum foil or foods packaged in aluminum foil directly on the flame.

⚠️ WARNING

Oven

1. Use care when opening the oven door. Let hot air or steam escape before removing or replacing food.
2. Do not heat unopened food containers in the oven. Build-up of pressure may cause a container to burst and result in an injury.
3. Keep the oven vent ducts unobstructed.
4. Place oven racks in desired location while the oven is cool. If a rack must be moved while the oven is hot, use a dry potholder.
5. Do not use aluminum foil to line the oven bottom. Aluminum foil can cause a fire and will seriously affect baking results.
6. Do not touch the interior surfaces of the oven during or immediately after use. Do not let clothing or other flammable materials contact the bake or broil burners. Although, these surfaces may be dark in color they can still be hot enough to burn.
7. Other areas of the oven can become hot enough to cause burns, such as vent openings, window, oven door and oven racks.
8. Do not use the oven cavity for storage space.

Due to the nature of cooking, fires can occur as a result of overcooking or excessive grease. Although a fire is unlikely, if one occurs proceed as follows:

Surface Burner Fires

1. Do not turn on the vent hood. The fan can spread the flames.
2. Smother the fire with a non-flammable lid or use a Class "ABC" or "BC" fire extinguisher.

Oven Fires

1. Do not open the oven door.
2. Turn all controls to "OFF".
3. As an added precaution turn off the electricity at the main circuit breaker or fuse box and the gas at the main supply valve.
4. Allow the food or grease to burn itself out in the oven.

If smoke or fire persist call your local fire department!

Installation Instructions

Cabinet Cutout and Clearances

To prevent possible floor damage do not remove the corrugated shipping pad from the range until it is ready to be placed into the cutout. The range is heavy and requires more than one person to handle it. Always use proper lifting methods.

Prepare the cutout as shown (right).

1. The range must be installed flush to the rear wall. It can be installed flush with the side cabinets if desired.
2. The space between the side wall and the range top must be a minimum of 4".
3. There must be at least 30" between the cooktop surface and the bottom of an unprotected wood or metal cabinet. The unprotected surface must also be at least equal to the width of the range.
4. The maximum depth of the cabinets installed above the range is 13".
5. Seal any openings in the wall behind the range or on the floor under the range.

Cabinet Cutout and Clearances

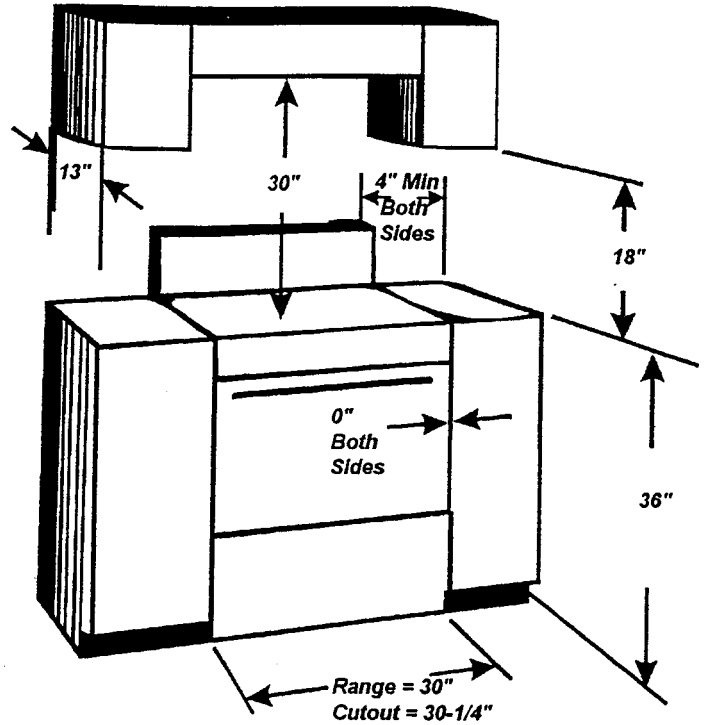

Dimensions For Bolting The Range To The Floor

When installed in mobile housing the range must be bolted to the floor. See illustrations below for bolting the range to the floor.

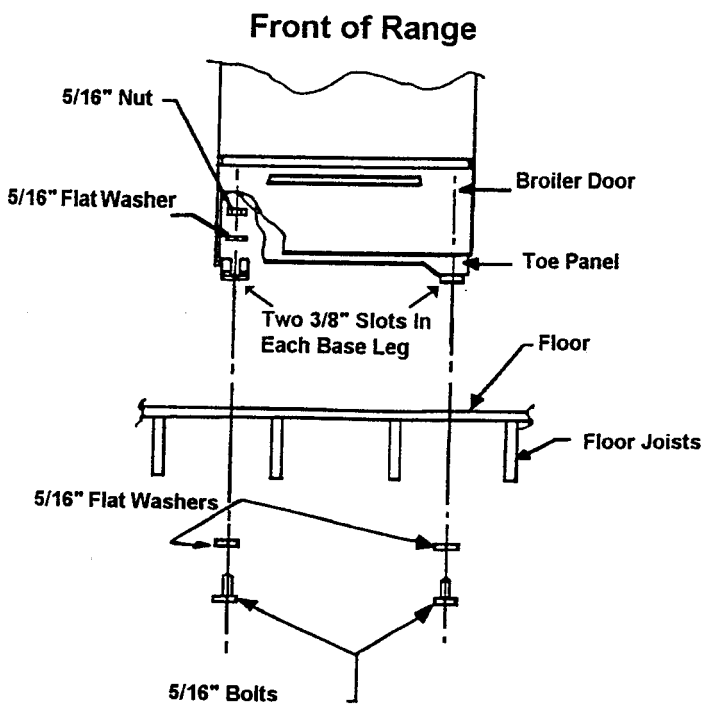

Bottom of Range

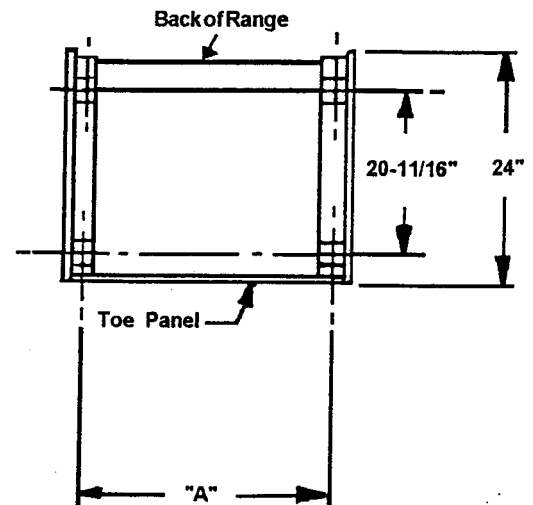

Unit Size	Dimension "A"
20"	16-3/4"
24"	20-3/4"
30"	26-3/4"
36"	32-3/4"

Making the Gas Connection

Before connecting this appliance to the gas supply system, the installation must conform with local codes or in the absence of local codes, with the National Fuel Gas Code, ANSI Z223.1-Latest Edition.

In Canada the installation must conform with the current Natural Gas Installation Code, CAN/CGA-B149.1 or the current propane installation code, CAN/CGA-B149.2, and with local codes where applicable.

The installation of appliances designed for manufactured or mobile homes must conform with the Manufactured Home Construction and Safety Standard, Title 24 CFR, Part 3280 or, when such standard is not applicable, the Standard for Manufactured Home Installations, ANSI A225.1/ NFPA 501A, (In Canada CAN/CSA-Z240 Mobile Homes) or with local codes if applicable.

Location of the Pressure Regulator

For the location of the pressure regulator see drawing on right.

Hard Piping

The gas connection can be made with 1/2" black iron hard piping. The amount of piping needed will depend on the location of the service stub. The connection should be made as illustrated on the right.

Flexible Connector

The gas connection can also be made using an AGA or CGA design certified flex connector.

⚠ WARNING

To Avoid the Risk of a Gas Leak or Fire:
Use only a new flexible connector that has been design certified by AGA or CGA.
Do not reuse and old connector. Do not reuse a connector if you move the appliance.

The manual shut off valve must be installed in an accessible location external to the range. The consumer must know how and where to turn off the gas.

Pipe joint compound must be resistant to the action of LP/Propane or Natural Gas.

Location of the Regulator

Back of Range

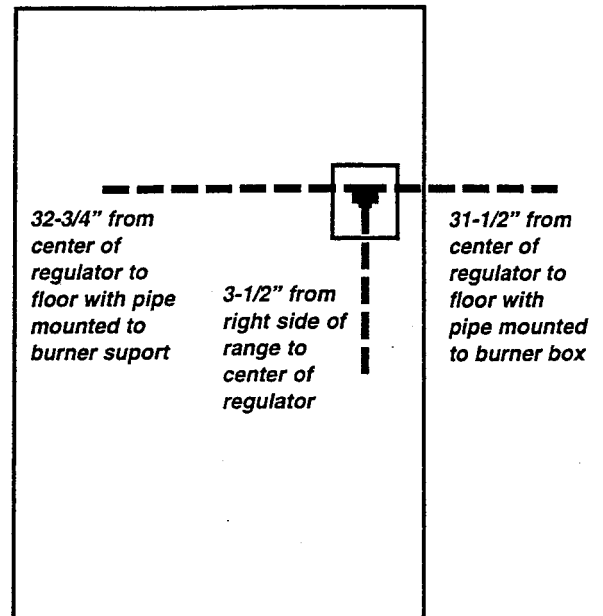

Hard Piping

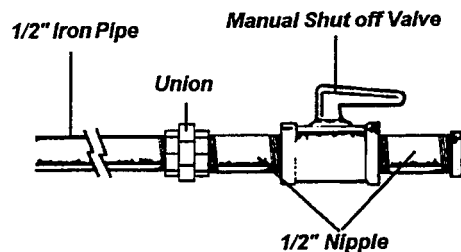

Flexible Connector

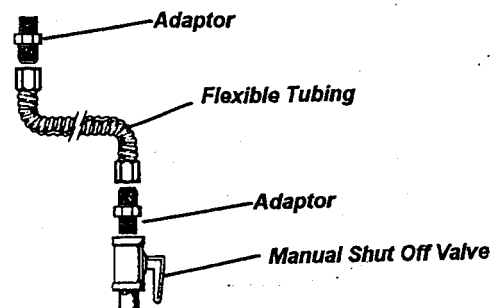

Installation Instructions

Making the Electrical Connection

If an external electrical source is used, it must be electrically grounded in accordance with local codes, or in the absence of local codes, with the National Electric Code ANSI/NFPA No. 70-latest edition (or in Canada with the current CSA Standard C22.1, Canadian Electric Code, Part 1.)

If the range has electrical components, it is equipped with a three prong grounding plug for protection against shock hazard. It must be plugged into a properly grounded three prong wall receptacle. Do not cut or remove the grounding prong from this plug. The gas piping cannot be used as a ground.

⚠ WARNING

To avoid the risk of electrical shock, burn or serious personal injury this unit must be properly grounded and plugged into a properly grounded three-prong wall receptacle.

Three Prong Grounding Plug & Receptacle

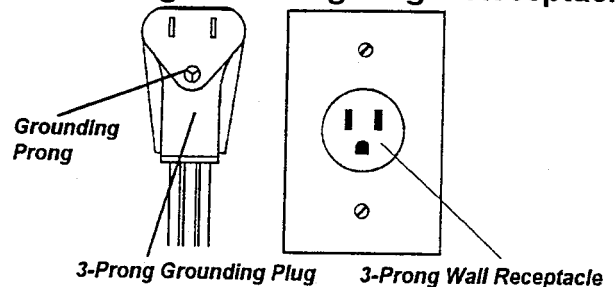

Pressure Testing the Gas Supply

The appliance and its individual shut-off valve must be disconnected from the house gas supply piping system during any pressure testing of the system at test pressures in excess of 1/2 psig (3.5 kPa).

The appliance must be isolated from the house gas supply piping system by closing its individual manual shut-off valve during any pressure testing of the gas supply piping system at test pressures equal to or less than 1/2psig (3.5 kPa).

The gas supply pressure for checking the regulator setting must be at least 1" WCP above the manifold pressure shown on the rating plate.

Testing For Gas Leaks

1. After the gas connection has been made, close all of the top burner valves and turn the gas supply on.
2. Test all connections in the gas supply line and in the range with soap suds for any leaks. If a leak is present bubbles will appear.
3. If bubbles appear, shut off the gas supply valve.
4. Correct the leak by tightening the joint if it is a factory fitting, or unscrewing it completely and applying additional pipe joint compound if it is not a factory fitting.
5. After the connections have been re-tightened, open the gas supply valve and re-test for leaks.
6. Any connections that may have been disturbed during testing need to be re-tested.

⚠ WARNING

To avoid the risk of fire, never use a lighted match or flame when testing for gas leaks.

Lighting the Top Burner Standing Pilot Flame

(Some Models)

1. Turn top burner controls to "OFF".
2. Light both top burner pilots using a match.
3. Remove the shipping screw securing the burner to the burner box. Each burner has one screw. The screw is next to the standing pilot. The screws are not necessary for cooking. Removing the screw will allow the burners to be removed for cleaning.
4. The pilot flame should be 1/4" to 3/8" high and centered in the pilot housing. If the flame is too high carbon soot will accumulate under to cook-top. Turn the pilot adjustment screw until the flame has the correct appearance. (see right)

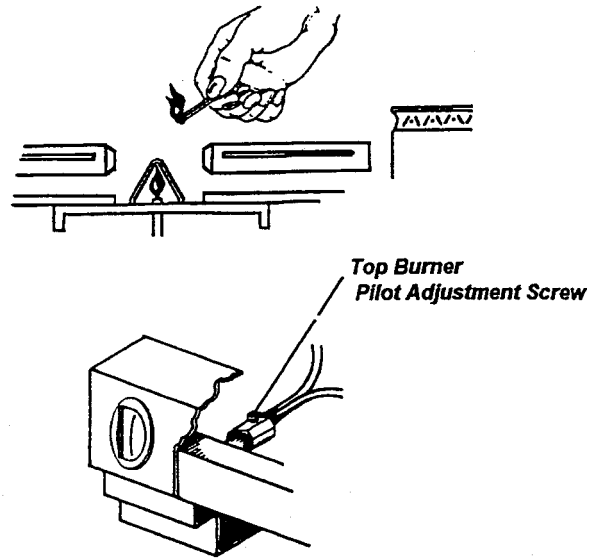

Adjusting the Top Burner Flame Size and Shape

A burner flame should be clean blue flame with a distinct inner cone approximately 1/4" to 1/2" long. If the flame is noisy or blowing it is getting too much air. If the flame is soft and lazy it is getting too much gas.

If the flame needs adjustment follow the steps below.

1. Remove the burner grates and caps if supplied.
2. If range has open burners lift top and go to number 5.
3. If range has sealed burners remove burner body screws and pull burner body upwards and disconnect the ignitor wire.
4. Remove venturi assembly screws and carefully remove maintop.
5. Loosen the air shutter lock screw.
6. Open or close the shutter depending on the appearance of the flame.
7. When the flame is properly adjusted, tighten the lock screw.
8. Re-assemble the burners and maintop.

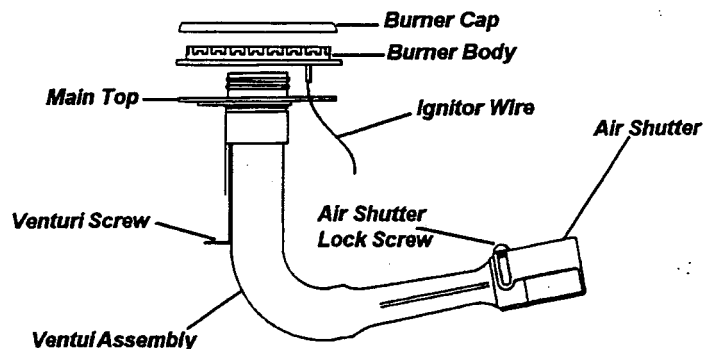
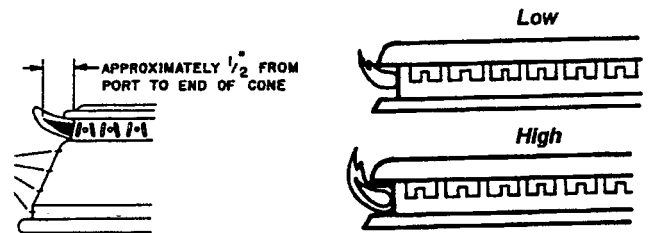

Installation Instructions

Lighting the Oven Burner Standing Pilot

(Some Models)

The range will have either a standing pilot light which must be lit initially, or a spark ignition system, which is electrically operated. To identify which system is present see the illustrations on the right. If the range has a standing pilot system use the steps below to light the pilot. If the range has spark ignition it will not have a standing pilot.

1. Remove the broiler carriage. (see page 14 for carriage illustration)
2. Turn the thermostat knob to warm.
3. Hold a lit match as shown until the pilot lights.
4. Quickly remove your hand from the broiler compartment after the pilot is lit.

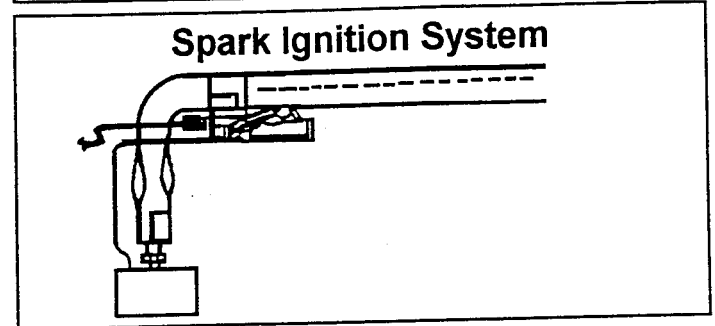
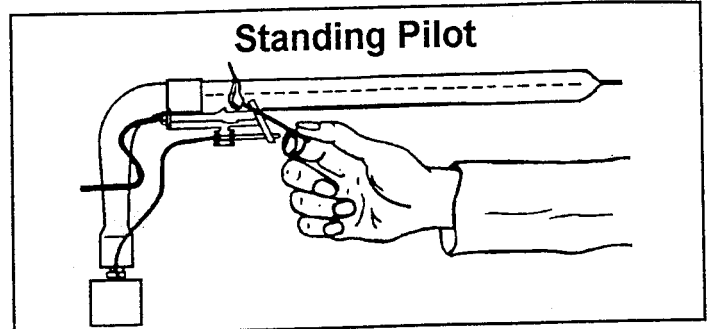

Adjusting the Oven Burner Flame Size and Shape

(Some Models)

The oven burner flame is factory adjusted, however, it should be checked to ensure proper size and shape. The flame should have an inner cone of bluish-green and an outer mantle of dark blue. The flame should be soft in character. If the flame is not properly adjusted follow the steps below.

1. Loosen the screw on the air shutter.
2. Move the air shutter closed to decrease or open to increase the amount of air to the flame.
3. When the flame is properly adjusted tighten the lock screw.

Sectional View of Oven Burner Flame

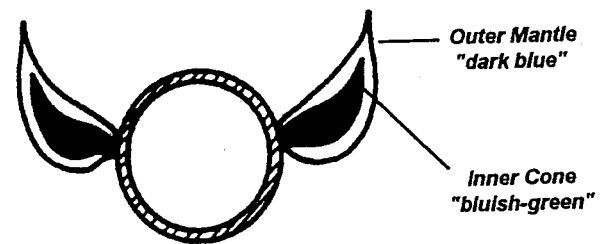

Oven Burner Air Shutter and Lock Screw Location

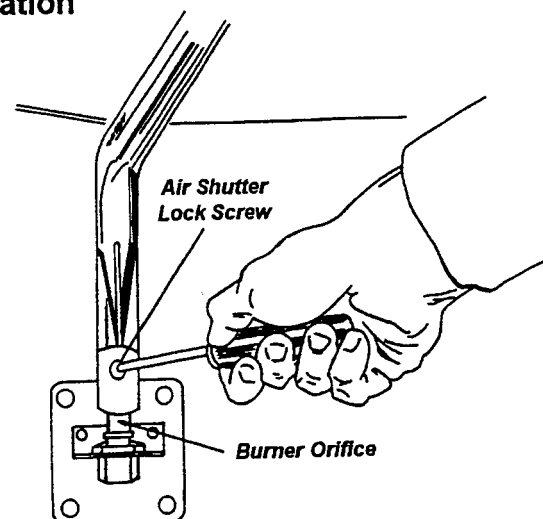

Converting from Natural Gas to LP/Propane Gas

Converting the Pressure Regulator For Use With LP/Propane

1. Remove the cap from the pressure regulator.
2. Invert and re-install cap. (see right)
3. Verify letters LP show in the cap. (see right)

Converting the Top Burners For Use With LP/Propane

1. Lift off the burner grates (and caps if supplied).
2. If range has open burners lift the top and go to number 5.
3. If range has sealed burners remove burner body screws and pull burner body upwards and remove the ignitor wire. (see page 6 for illustration)
4. Remove venturi assembly screws and carefully remove maintop.
5. For sealed burners only, close the air shutter until there is a 1/8" opening.
6. Behind each control knob there is an orifice hood. Turn all four orifice hoods down onto the pins approximately 1-1/2 to 2 turns until snug. Care should be taken not to damage the pins or distort the hole through the center of the pins.
7. Re-assemble the burners and maintop.

Converting the Oven Burner For Use With LP/Propane

1. Remove the broiler drawer.
2. Locate the orifice hood and turn the hood down on to the pin, approximately 1-1/2 to 2 turns until snug. Care should be taken not to damage the pins or distort the hole through the center of the pins.

Converting the Thermostat

1. Remove the oven temperature control knob.
2. Turn the thermostat selector to the L.P. gas setting.

When the conversion is complete, place the burner bodies and caps on the venturi, light all of the flames and check the flame size and appearance. If flames need to be adjusted see pages 6 and 7. If the range needs to be converted back for use with natural gas reverse the instructions above.

⚠ WARNING

To avoid the risk of serious personal injury or property damage the range must be converted correctly. Improper conversion or flame adjustment will produce carbon monoxide, which is a poisonous gas.

Pressure Regulator

LP/Propane Gas

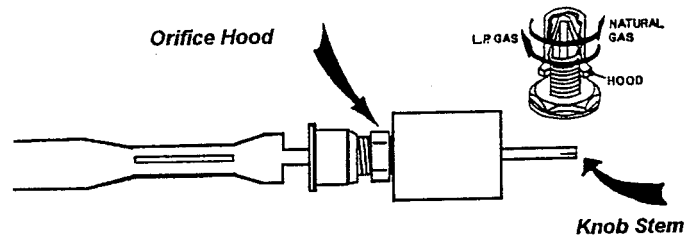
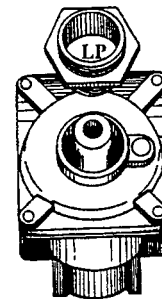

Oven Burner

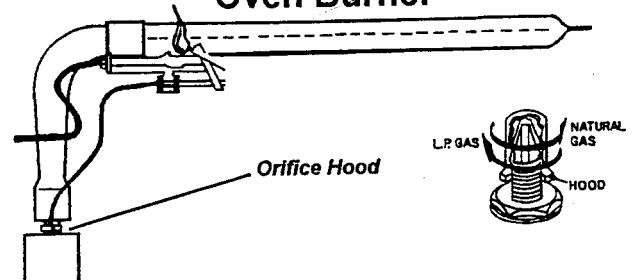

Temperature Control Knob

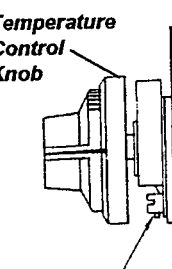

Selector

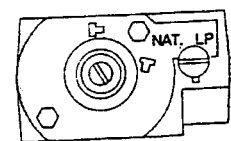

NAT. LP NAT. LP
Off Natural Propane

Installation Instructions

Installing the Anti-Tip Bracket

Without Cabinets

To reduce the risk of tipping, the range must be secured by a properly installed anti-tip bracket.

1. Center and secure the bracket to the wall or floor 1-7/8" from the side of the cabinet and against the back wall.
2. Mark either the wall or the floor where the screws will be mounted.
3. Drill two 1/8" holes in the wall or two 1/8" holes in the floor to secure the bracket. If mounting into wood flooring, drill two 1/8" holes as designated above. If mounting into concrete use a masonry drill bit. Drill two 1/4" holes and insert plastic anchors. (see right)
4. Position bracket and mount using supplied screws.
5. Screw the rear leveling legs into the range. Do not allow more than 1/8" of the leg to be extended.
6. Center the range in the cabinet space and slide it into position over the bracket. (see right)
7. Open the broiler drawer and look under the range using a flashlight to be sure the anti-tip bracket has been installed correctly.
8. The front leveling legs can now be adjusted up to 1/8".
9. If the range is moved to a new location the anti-tip bracket must also be relocated and re-installed.

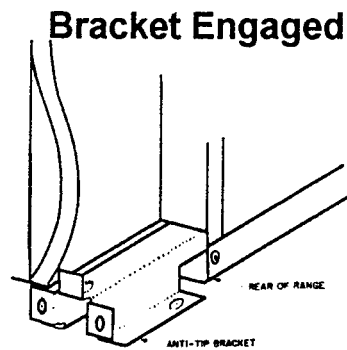
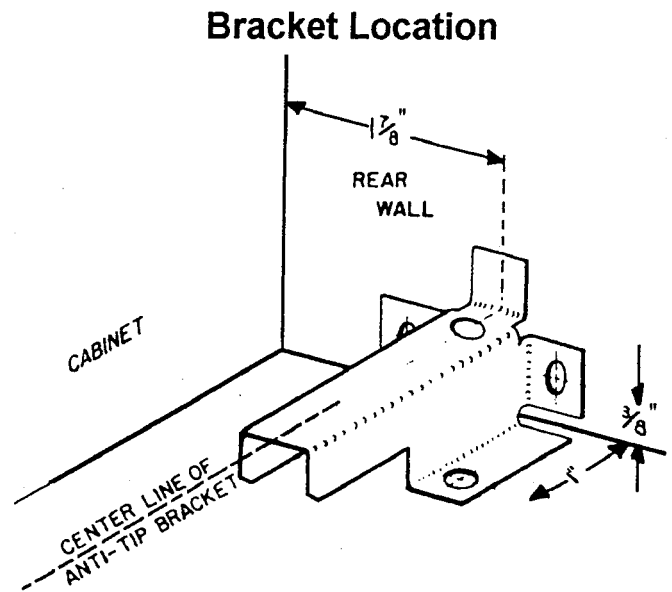

Bracket Location Without Cabinets

Without Cabinets

If the range is not installed against a cabinet follow the steps below.

1. Mark the center line 1-7/8" from where the side of the range will be.
2. Center the bracket as shown and place it against the line where the back of the range will be. Install the bracket using steps 2 through 4 above.
3. Slide the range into position over the bracket.
4. Open the broiler drawer and look under the range using a flashlight to be sure the anti-tip bracket has been installed correctly.

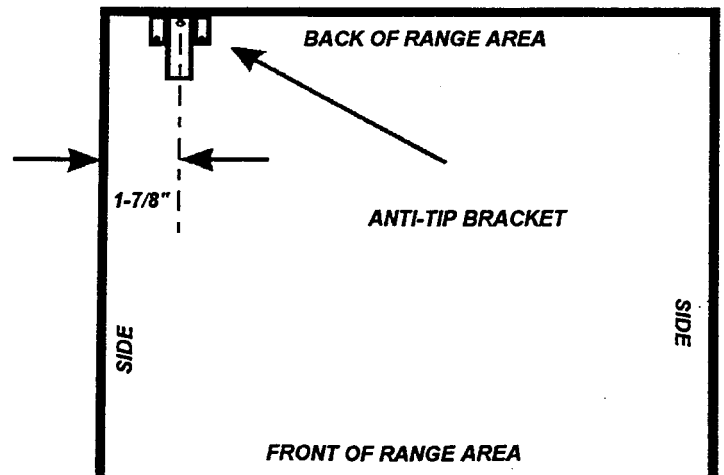

Setting the Time of Day

Setting the LED Electronic Clock/Timer

1. Push the CLOCK button.
2. Push the HOUR button to display the correct hour of day.
3. Push the MINUTE button to display the correct minutes.

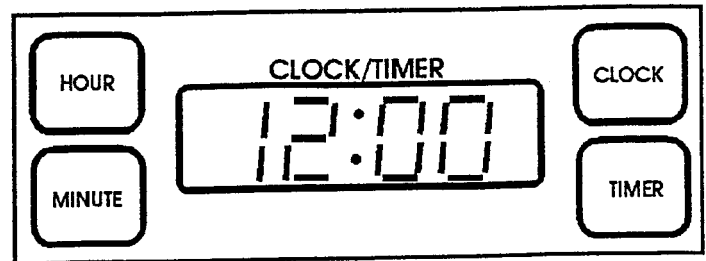

Setting the LED Electronic Clock/Timer Timer (Some Models)

1. Push the TIMER button.
2. Push the HOUR and/or MINUTE buttons to set the desired amount of time. The timer can be set from 1 minute to 1 hour and 59 minutes.
3. When the time has elapsed, press the CLOCK button to cancel the beep.

Cancel the LED Electronic Clock/Timer

1. Push in and hold the MINUTE button until the display reads 00:00.
2. Press the CLOCK button to cancel the beep.

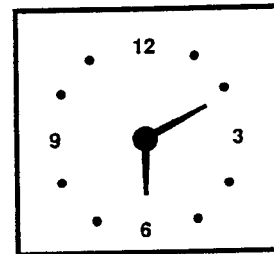

Analog Clock

Turn the knob in the center of the clock until the hands point to the correct time of day.

Selecting Cooking Utensils

Cooking Utensils

Type	Response To Temperature Changes	Recommended Usage
Aluminum	Heats and Cools Quickly	Frying, Braising, Roasting
Cast Iron	Heats and Cools Slowly	Low Heat Cooking, Frying
Copper, Tin Lined	Heats and Cools Quickly	Gourmet Cooking, Wine Sauces, Egg Dishes
Enamelware	Response Depends on Base Metal	Low Heat Cooking
Glass Ceramic	Heats and Cools Slowly	Low Heat Cooking
Stainless Steel	Heats and Cools at Moderate Rate	Soups, Sauces, Vegetables, General Cooking

Use and Care

Cooking Utensils

1. Use the proper pan size. Do not use a pan that has a bottom smaller than the flame.
2. Care should be taken when using glazed cooking utensils. Some glass, glass\ceramic, earthenware or other glazed utensils will break due to sudden temperature changes.
3. Select utensils without broken or loose handles. The handle should not be heavy enough to tilt the pan.
4. Select utensils with flat bottoms.

Determining If a Pan Has a Flat Bottom

1. Rotate a ruler along the bottom of the pan. If the pan is not flat there will be gaps between the bottom of the pan and the edge of the ruler.
2. A small groove or mark on a pan will not effect cooking times. However, if a pan has a large gap or an extremely uneven bottom, it will not be energy efficient.

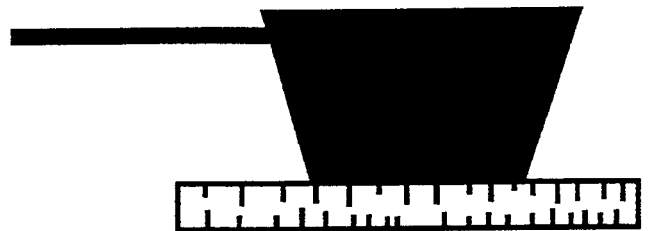

Using the Top Burners

Operating the Top Burners

1. Push in and turn the burner control to LITE.
2. When the burner is lit, turn the control to the desired setting.

When Finished

Turn all controls to OFF.

Operating the Cooktop During A Power Failure

1. Turn the control knob to LITE.
2. Hold a lit match at the corresponding burner.
3. When the burner is lit, turn the control to the desired setting.

When Finished

Turn all controls to OFF.

⚠ WARNING

To avoid the risk of serious personal injury, property damage or fire do not leave the surface burners unattended while in operation. Grease and spillovers can ignite causing a fire.

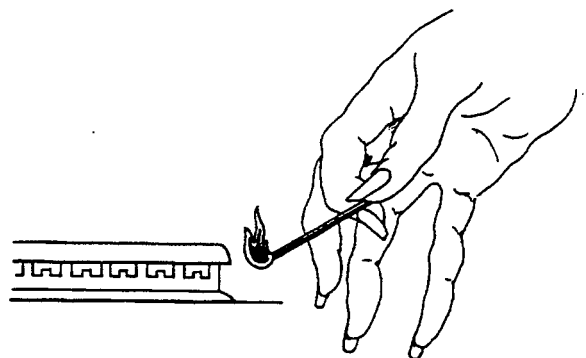

Using the Oven

Oven Rack Placement

1. Pull rack forward to the stop position.
2. Raise the forward edge and pull it out of the oven.

Pan Placement

Baking pans and cookie sheets should be kept two inches from the side and rear walls. If baking pans are placed on different racks, they should be staggered so that one is not located directly under another. This will prevent uneven browning of foods.

Operating the Oven (Baking/Roasting)

1. Turn the temperature control knob to the desired temperature.
2. Allow up to 40 seconds to light.
3. Depending on the recipe the oven may need to be pre-heated 10 to 15 minutes.

When Finished

Turn the temperature control knob to OFF.

Operating the Oven During a Power Failure

1. Remove the broiler carriage. (see page 14)
2. Turn the temperature control knob to the desired temperature past the WARM mark).
3. Hold a lit match on the top front part of the oven burner pilot. (see illustration)
4. When the pilot lights, quickly remove the match from the oven. Allow up to 40 seconds for the burner to light.
5. Carefully replace the oven bottom or broiler carriage.

Oven Rack

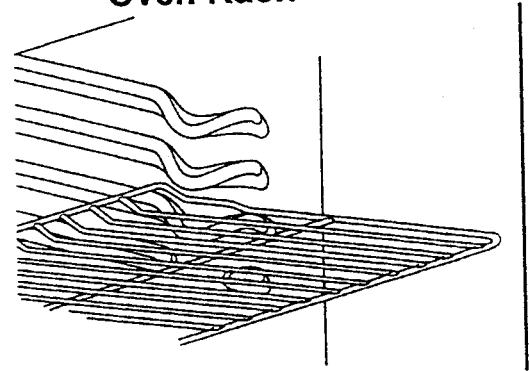

Correct Pan Placement

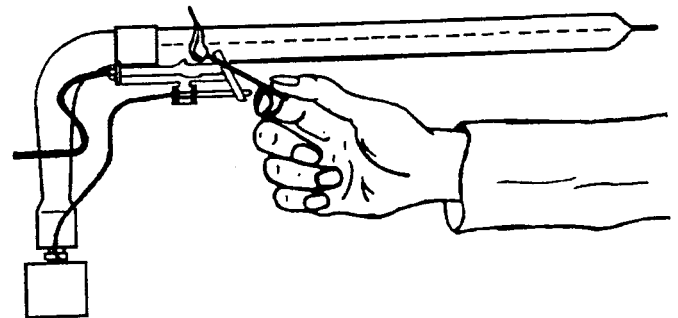
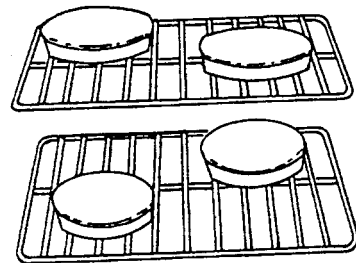

Use and Care

Baking

Food	Temperature	Minutes
Bread	400F	45-60
Biscuits	450F	12-15
Muffins	425F	20-25
Nut Bread	400F	50-60
Corn Bread	400F	30
Drop Cookies	350F-375F	20-25
Roll Cookies	375F-400F	8-12
Brownies	350F	25-30
Pie Shells	475F	10-15
Apple Pie	400F	45-60
Custard Pie	400F	35-45
Berry Pie	425F	45-60
9" Layer Cake	350F	30-35
Cup Cakes	375F	20-25
Fruit Cake	250F-275F	2-4 hours
Angel Food Cake	350F	40-50

Roasting

Food	Temperature	Minutes Per Pound
Beef Roast (rare)	325F	20-25
Beef Roast (med.)	325F	26-30
Beef Roast (well)	325F	33-35
Rolled Roast (rare)	325F	32-36
Rolled Roast (med.)	325F	36-40
Rolled Roast (well)	325F	43-45
Fresh Ham (whole)	325F	22-28
Fresh Loin	325F	35-40
Shoulder or Butt	325F	40-45
Shoulder or Picnic	325F	35-40
Chicken 4lbs to 5lbs	375F	22-27
Chicken over 5lbs	375F	27-32

Note: Baking time will vary with temperature of ingredients and size and type of utensil being used. Follow these charts only as a guide.

Using the Broiler

Broiling Tips

1. Cut the edges of the meat to prevent curling.
2. Place the food on a cold ungreased broiling pan. If the pan is hot the food will stick.
3. Fish should be broiled with the skin side down.
4. Season the meat after it has browned.
5. Remove excess fat from meat before broiling.
6. All food except fish should be turned at least one time.

Operating the Broiler

Turn the temperature control knob to BROIL.

When Finished

Turn all controls to OFF.

CAUTION

To avoid risk of fire, place broiler grid correctly on the broiler pan. Incorrect placement will not allow grease to drain properly. The broiler grid has cut corners that must be matched with the corners on the broiler pan. Do not line the broiler grid with foil. Foil may trap grease on top of the pan causing it to ignite.

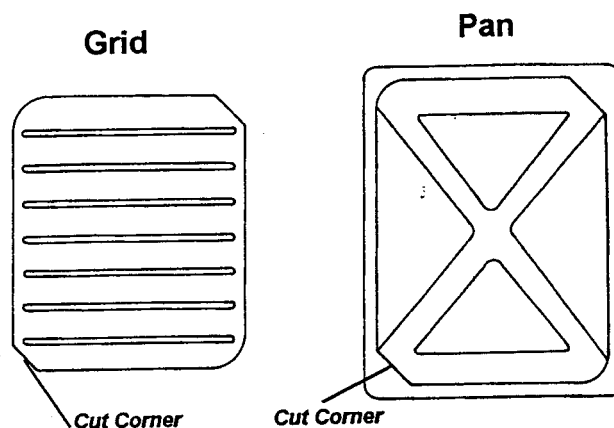

Proper Pan Placement

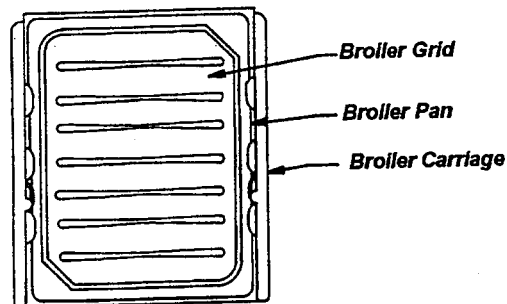

Cleaning the Broiler

1. Pull the broiler grid and pan out of the broiler carriage.
2. Grasp the sides of the broiler carriage and pull upward until it is released by the front clip.
3. Pull the carriage forward sliding it off of the rear tab.
4. To remove dried or cooked on soil, soak the removable parts in hot soapy water.
5. All pans must be replaced before using the oven.

When Replacing

The broiler carriage must be locked under the rear placement tab before attempting to snap the clip into the front.

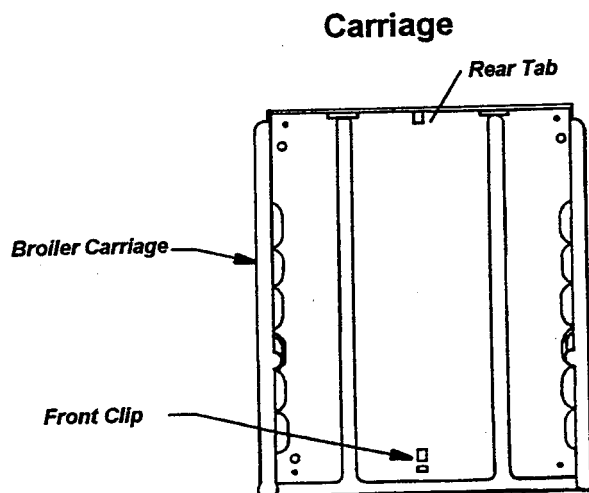

Use and Care

Cleaning Range Parts

Range Part	Cleaning Materials	General Directions
Bake, Broil Burners		Do not clean the bake or broil burner. Any soil will burn off during cooking.
Broiler Pan and Grid	Soap and a Nonabrasive Plastic Scouring Pad	Drain fat, cool pan and grid slightly. (Do not let soiled pan and grid stand in range to cool.) Sprinkle with soap. Fill the pan with warm water. Let pan and grid stand for a few minutes. Wash and scour if necessary. Rinse and dry. Option: The broiler pan and grid may also be cleaned in the dishwasher.
Control Knobs	Mild Soap and Water	Pull off knobs. Wash gently but do not soak. Dry and return controls to range, making sure to match flat area on the knob to the flat area on the shaft. Option: The knobs may be cleaned in the dishwasher.
Inside Continuous Cleaning Oven	Soap and Water	Cool before cleaning. Frequent wiping with mild soap and water will prolong the time between major cleanings. Be sure to rinse completely. For extra dried on soil a mild abrasive can be used. Never use strong abrasives, gritty cleaners, commercial oven cleaners or steel wool.
Inside Porcelain Coated Oven	Soap, Water, Commercial Oven Cleaners	Cool before cleaning. Frequent wiping with soap and water will prolong the time between major cleanings. If using commercial oven cleaner follow the manufacturer's cleaning instructions. Be sure to rinse and dry oven completely.
Oven Racks and Front Panel	Soap and Water	For heavy soil, clean by hand and rinse completely. Remove the front panel and oven racks for ease in cleaning. Be sure the panel is dry before replacing it.
Burner Grates and Caps (Some Models)	Soap and Water	Cool before cleaning. For heavy soil soak in warm soapy water. Never use strong abrasives, gritty cleaners or steel wool. Option: The grates and caps may be placed in the dishwasher.
Outside of Range and Backguard	Soap and Water	Wash all glass with cloth dampened in soapy water. Rinse and polish with a dry cloth. If knobs are removed, do not allow water to run down inside the surface while cleaning.

Hard to Clean Yellow or Brown Stains

Yellow or brown stains sometimes occur when baking or broiling foods with a high fat content. These types of stains appear on the lower front control panel and backguard. The stains should be cleaned immediately after cooking. The longer a stain is allowed to remain on the range the more difficult it will become to remove.

Clean the stains with a dampened cloth and nonabrasive or mild abrasive cleaner following the cleaner manufacturer's instructions. Rinse area thoroughly and polish with a dry cloth.

Maintenance

Removing the Oven Door

Remove the oven door for easier access when cleaning.

1. Open the door to the first stop position.
2. Grasp the door firmly on each side and lift it upward off the hinges.

Replacing the Door

1. Align the door with the hinge arms.
2. Slide the door down and into place. Be sure the door is completely down on the hinges.

CAUTION

Use care when removing the door. The door is heavy. The door can be damaged if it is dropped.

Do not place hands in the area of the hinges when the door is not in place. The hinges can snap closed and pinch your hands.

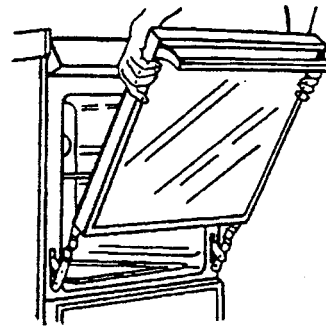

Removing the Oven Bottom

The oven bottom can be removed for ease in cleaning.

1. Note the position of the oven bottom.
2. Lift up on the rear of the oven bottom and pull it forward out of the oven.

Replacing the Oven Bottom

1. Face the oven bottom in the correct direction.
2. Place it in the oven and slide it to the rear until it drops into position.

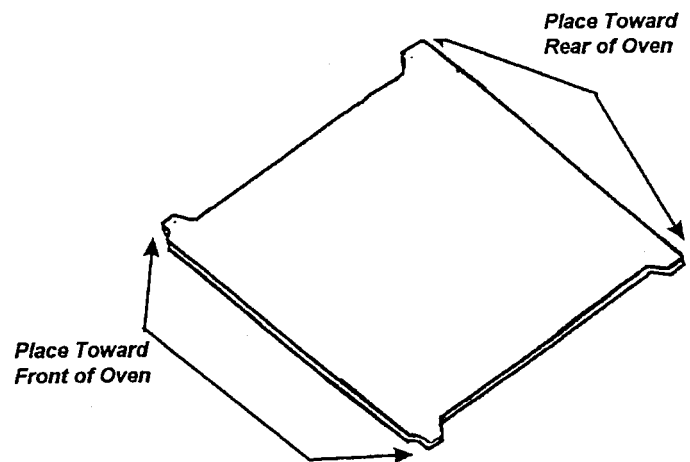

WARNING

To avoid the risk of severe personal injury or electrical shock turn the power off at the main circuit breaker before changing the bulb. Make sure the oven and light bulb are cool before replacing. Wear protective gloves.

Changing the Oven Light

1. Gloves must be worn to protect your hands when changing the bulb.
2. Disconnect the power to the range at the main circuit breaker.
3. Unscrew the light bulb counterclockwise.
4. Replace the bulb with a 40-watt appliance bulb.
5. Reconnect the power to the oven.

Use and Care

Adjusting the Oven Temperature

If foods are consistently underdone or overdone, make the following adjustments.

1. Pull off the temperature control knob. Turn the knob over.
2. Using a philips head screwdriver loosen the two screws on the pointer plate.
3. Turn the knob skirt to the next line. Each line is equal to 10°F. Do not move more than 10°F each time. Test the oven after increasing the temperature. Raising the oven temperature too high will adversely affect baking results.
4. Tighten the screws and replace the knob.

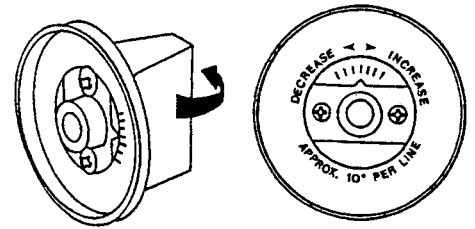

Before Calling For Service

Check these problems before calling for service.

Problem	Things to Check
Top Burners Not Lighting	<p>Make sure pilot is lit.</p> <p>Make sure burner ports (holes) on the side of the burner are not clogged.</p> <p>Make sure caps are on sealed burners correctly.</p> <p>Make sure non-sealed burners are on range correctly.</p> <p>Check air shutters for proper position.</p> <p>Make sure ignitors are not wet.</p>
Oven Light Not Working	<p>Check bulb for looseness.</p> <p>Check to see if bulb is burned out. If bulb is burned out, it should be replaced with a 40 watt appliance bulb.</p>
Oven Not Heating	<p>Make sure pilot is lit.</p> <p>Make sure range is connected to electrical power (when applicable).</p>
Oven Burner Cycles On and Off	<p>This is normal when cooking below broil.</p> <p>Burner should not cycle while broiling.</p>
Oven Temperature Is Not Accurate	<p>Do not try to measure temperature with a regular thermometer.</p> <p>Make sure the thermostat capillary bulb in the top part of the oven cavity is straight, not touching oven sides and not coated with cleaner or food.</p> <p>Check for blocked air vents.</p> <p>Aluminum foil will alter oven temperature.</p> <p>Oven bottom is not in position correctly.</p> <p>Not using correct utensil.</p>

When Service Is Required

The dealer from whom you purchased the appliance can give you the name of your nearest Authorized Service Center. Help them give you prompt service by giving them:

1. An accurate description of the trouble.
2. Complete model, serial, and manufacturing numbers located on the rating plate.
3. Proof of purchase (sales receipt on request)

Keep an accurate record of any service calls: what was done, who serviced the appliance, and the date of service.

We have a vast network of Authorized Service Centers in the U.S.A.. If you have a service problem that is not resolved please

**Write: Consumer Affairs Department
Amana Refrigeration, Inc.
Amana, Iowa 52204**

To locate an authorized servicer or if you have questions concerning product usage, installation, or warranty, call:

**CONSUMER INFORMATION LINE
TOLL FREE 1-800-843-0304**

**OUTSIDE U.S.A. CALL
1-319-622-5511**

Asure™

We are pleased to offer a long-term service protection on your new range. The Asure™ Extended Service Plan is specially designed to supplement the strong warranty. Asure provides budget protecting coverage on your appliance for up to five full years, covering parts, labor and travel charges.

Your participating Amana/Caloric/Sunray dealer has details or you can call or write us using the number or address listed above.

©1994 Amana Refrigeration, Inc.
Amana, Iowa 52204

Amana
A Raytheon Company

Part Number 07709204
Printed in U.S.A.